

# Isolation and Characterization of Aluminum Tolerance Genes in the Cereals: An Integrated Functional Genomic, Molecular Genetic and Physiological Analysis (IC69)

## Cornell University

Leon Kochian (PI)  
Edward Buckler  
Owen Hoekenga  
Jiping Liu  
Michael Lyi

## Embrapa Maize and Sorghum

Jurandir Magalhaes  
Claudia Guimarães  
Vera Alves  
Ubiraci Lana  
Robert E. Schaffert  
Cintia Coelho  
Andrea Carneiro  
Newton Carneiro

## Embrapa Wheat

Sandra Brammer

## Embrapa Rice and Beans

Rosangela Bevitori  
Pericles Neves

## Moi Univeristy

Samuel Gudu



# Global Distribution of Acid Soils

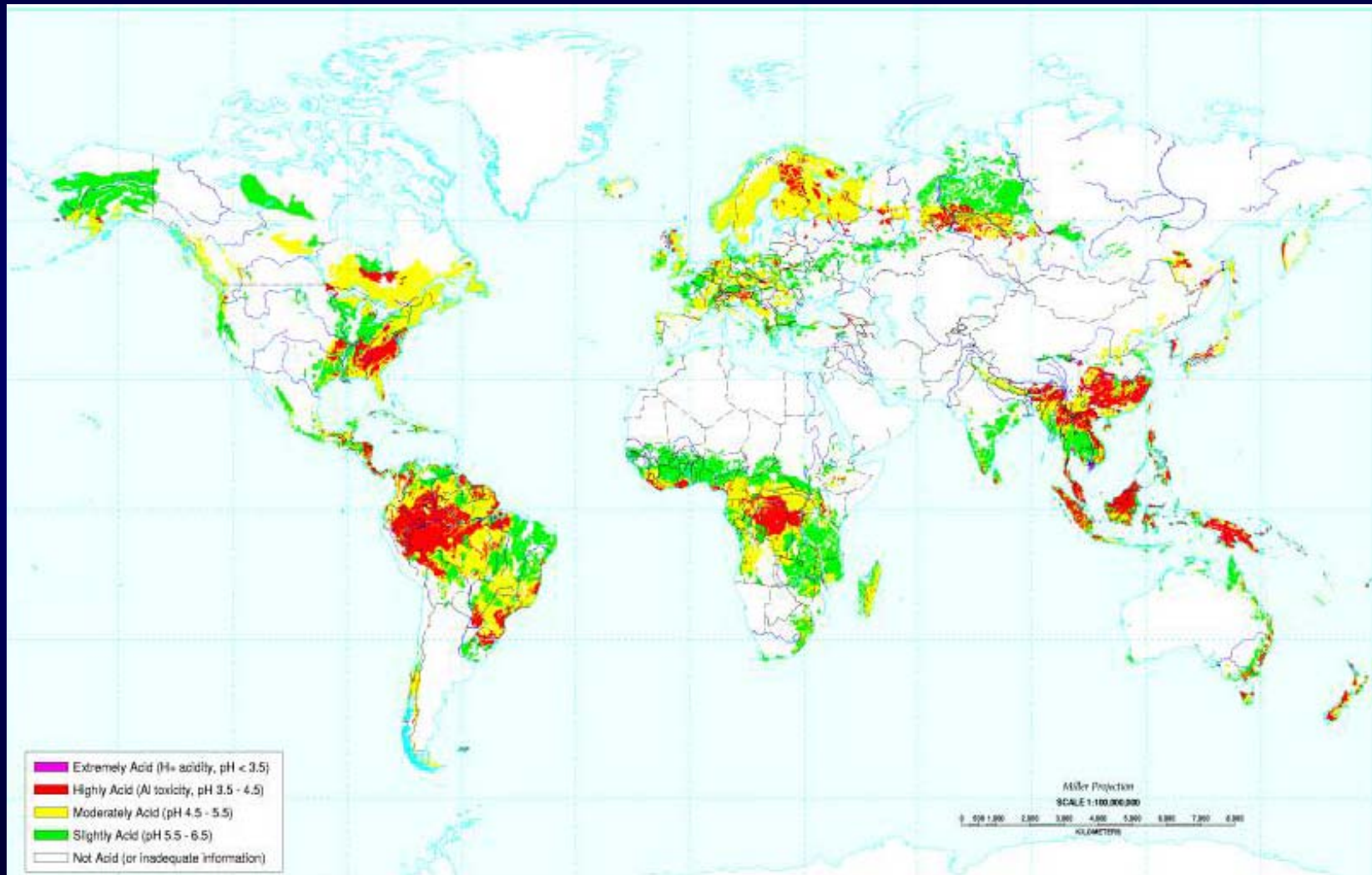

# Improving Crops for Cultivation on Al-Toxic Acid Soils

---

- Because of the agronomic importance of this problem, there is considerable interest in isolating Al tolerance genes and identifying associated physiological mechanisms
- The goal of our project is to use this type of information to develop crops better suited for cultivation on acid soils
- An interdisciplinary approach including genetics, molecular biology and physiology to identify and characterize Al tolerance genes and their associated mechanisms in maize and sorghum
- We also will use information from candidate genes from maize and sorghum identified in this project, as well as from recently identified candidates in wheat and Arabidopsis, to identify and verify the relevance of candidate Al tolerance genes in rice and the Triticeae.

# Research Objectives

---

## 1) Sorghum

- Verify the identity of the sorghum Al tolerance gene,  $Alt_{SB}$ , via molecular approaches and linkage disequilibrium mapping
- Identify elite  $Alt_{SB}$  alleles for use in marker assisted breeding and transgenic crop improvement
- Identify new sources of Al tolerance for gene pyramiding in sorghum

## 2) Maize

- Characterize near isogenic lines derived from both North and South American maize populations to define physiological mechanisms of Al tolerance
- Identify candidate genes via comparative and functional genomics-based strategies
- Verify candidate genes via LD-mapping

(Continued)

# Research Objectives

---

## 3) Rice and Triticeae

- Characterize Al tolerance in a diverse set of germplasm using standardized methodology
- Utilize comparative mapping in rice and the Triticeae to confirm or deny the importance of Al tolerance genes identified in sorghum and maize (homologs of *Almt-1* and *Alt<sub>SB</sub>*)

## 4) Deliverables for Africa (Moi University)

- New Al tolerant sorghum and maize genotypes, generated via biotechnology, will be evaluated for yield and other agronomic traits in a testing site developed at Embrapa Maize and Sorghum and transferred for testing in Africa. Embrapa Maize and Sorghum will provide technical support and training for field-testing in Africa.

**1<sup>st</sup> Year Research Progress:  
Sorghum Aluminum Tolerance**

# Sorghum Phenotypic Reactions to Al

## Hematoxylin staining



## Visual symptoms of root damage



# $Alt_{SB}$ : a major partially dominant Al tolerance gene in sorghum SC283 that is apparently not conserved to $Alt_{BH}$ in Triticeae

F<sub>2:3</sub>:BR007xSC283 ( $\{27\} \mu\text{M Al}^{3+} \text{ L}^{-1}$ )

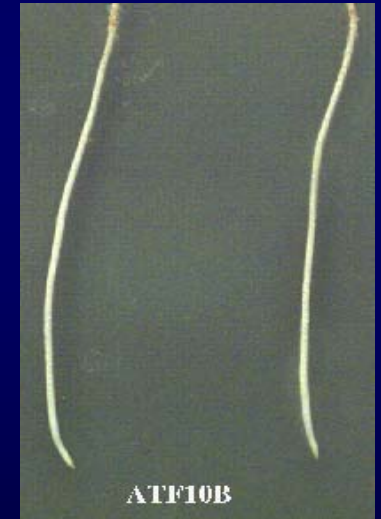
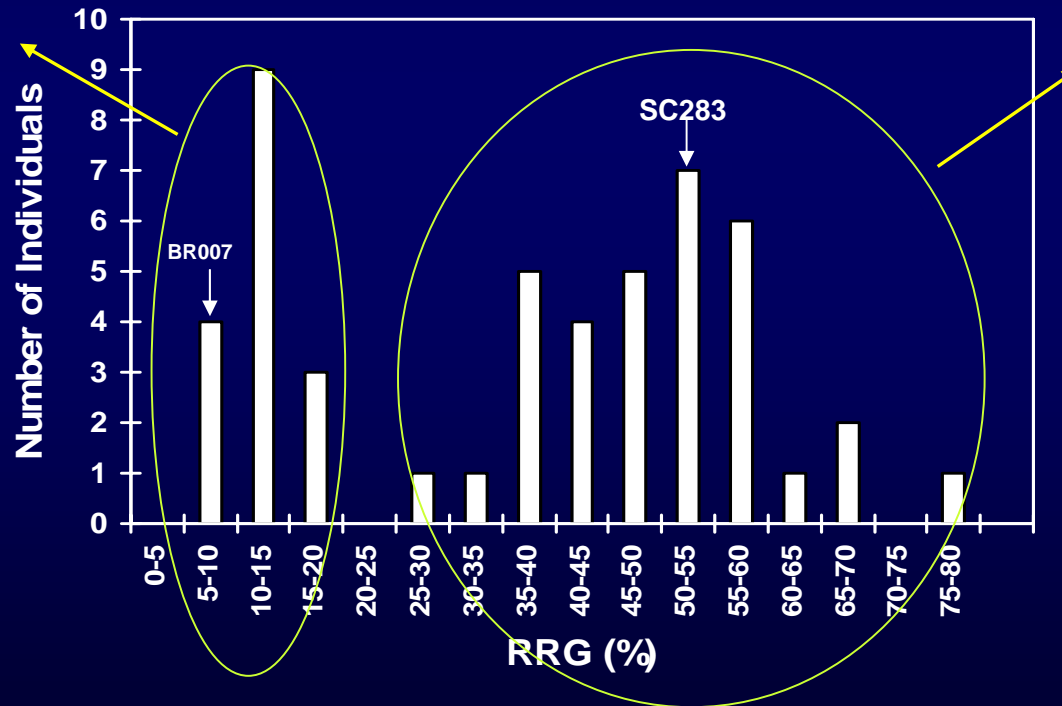

# Positional Cloning Supported by Comparative Mapping



Rice 1

<http://rgp.dna.affrc.go.jp/>

Sorghum 3

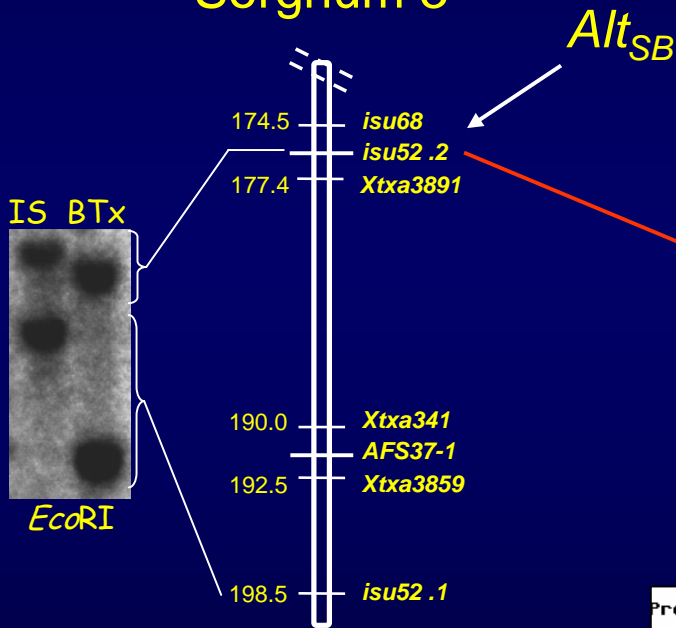

F<sub>6-8</sub>:BTx623 x IS3620C

Low resolution level

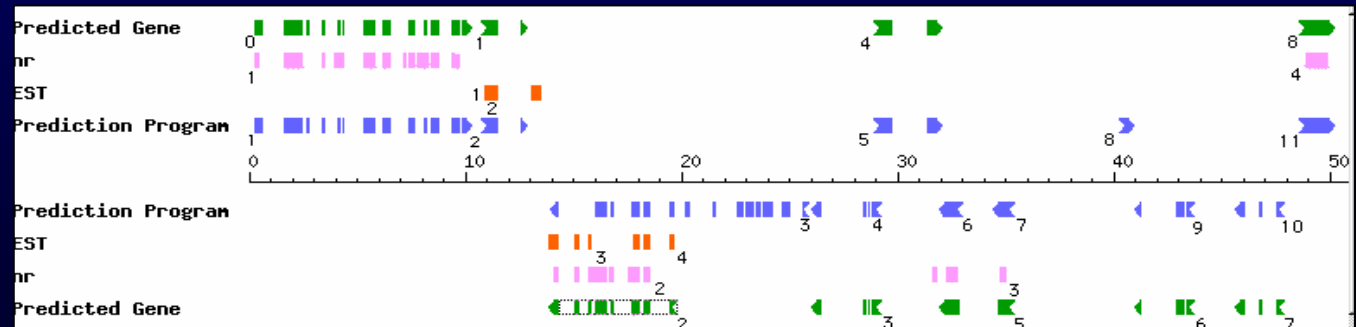
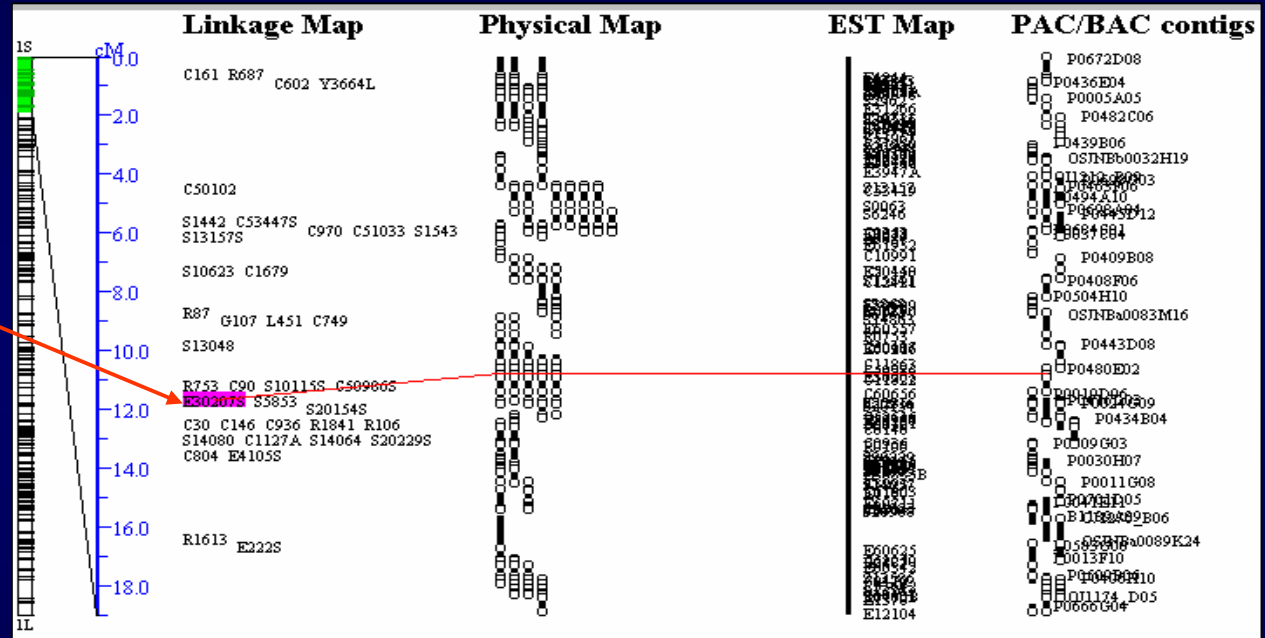

# Molecular Mapping of *Alt<sub>SB</sub>* and Anchoring onto the Sorghum Genetic Map

## Rice Chromosome 1

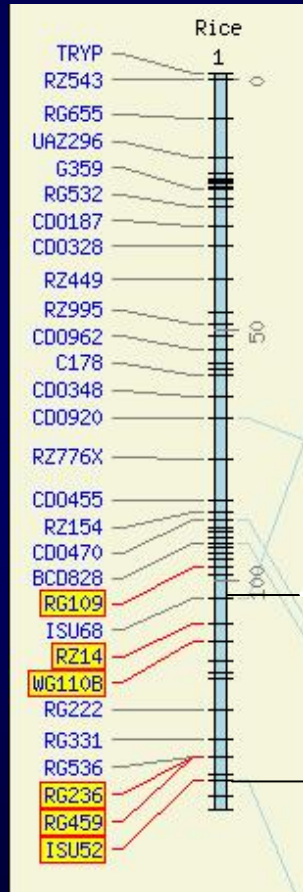

Major rice Al tolerance QTL

Collaboration with Patricia Klein - Texas A&M -

## Sorghum 3

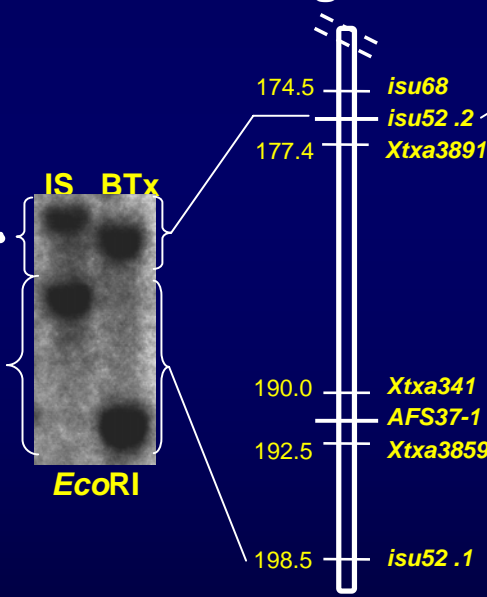

## BTx IS 007 283

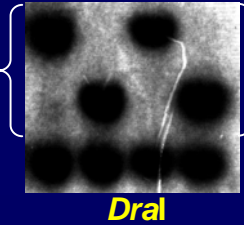

## Low resolution

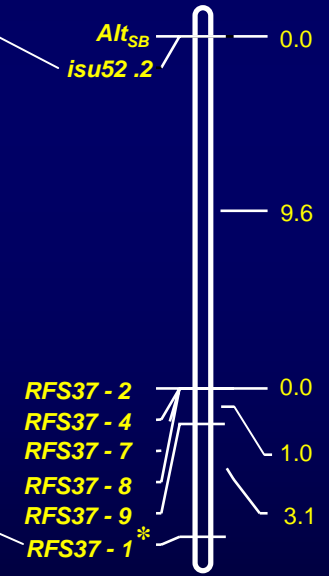

F<sub>6-8</sub>:BTx623 x IS3620C

F<sub>2</sub>:BR007 x SC283

# Positional Cloning of *Alt<sub>SB</sub>*

Intermediate resolution level

354 RILs  
BR007 x SC283

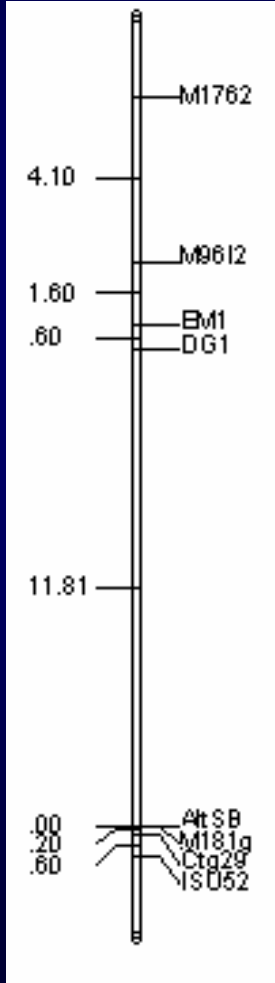

High resolution level

150 Kbp / cM

2200 F<sub>2</sub>

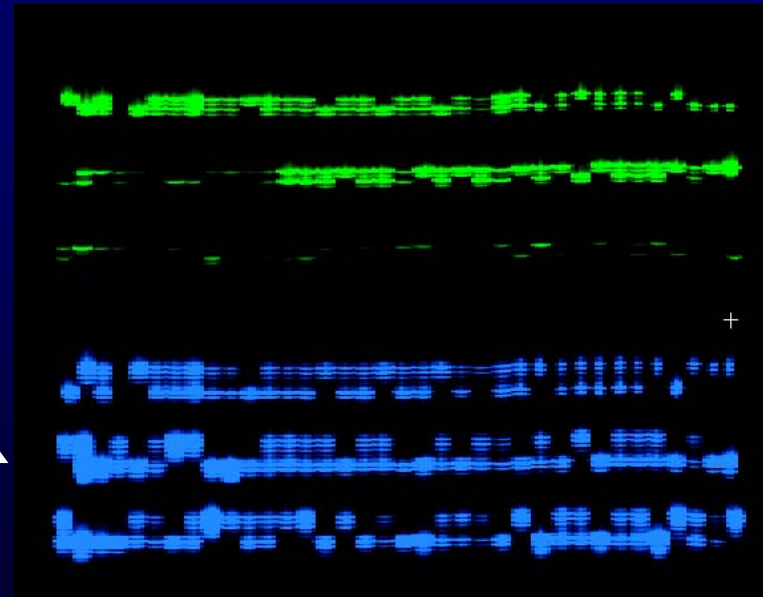
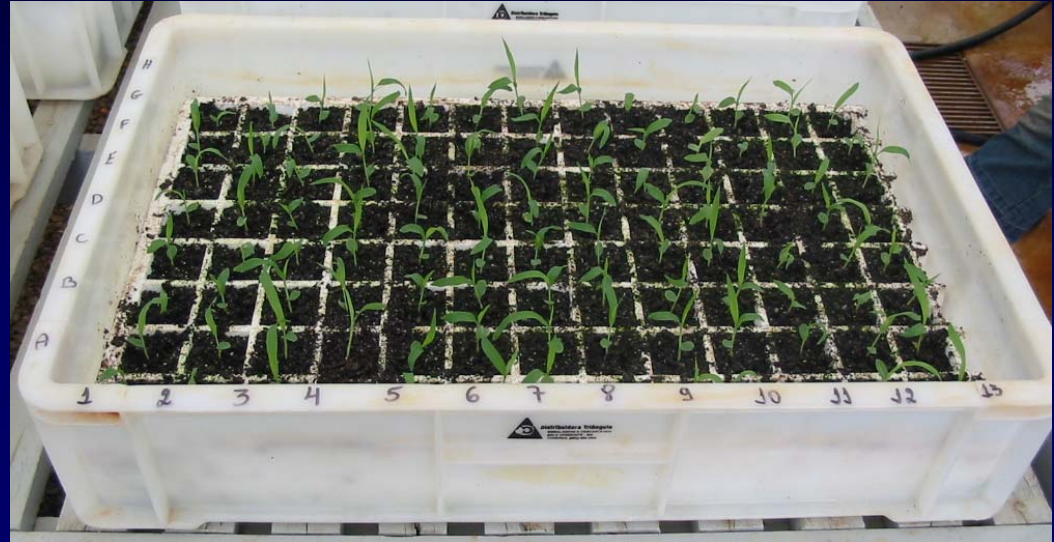
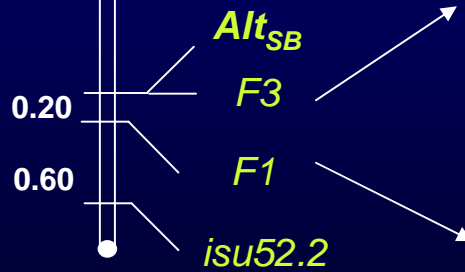

# Positional Cloning of $Alt_{SB}$

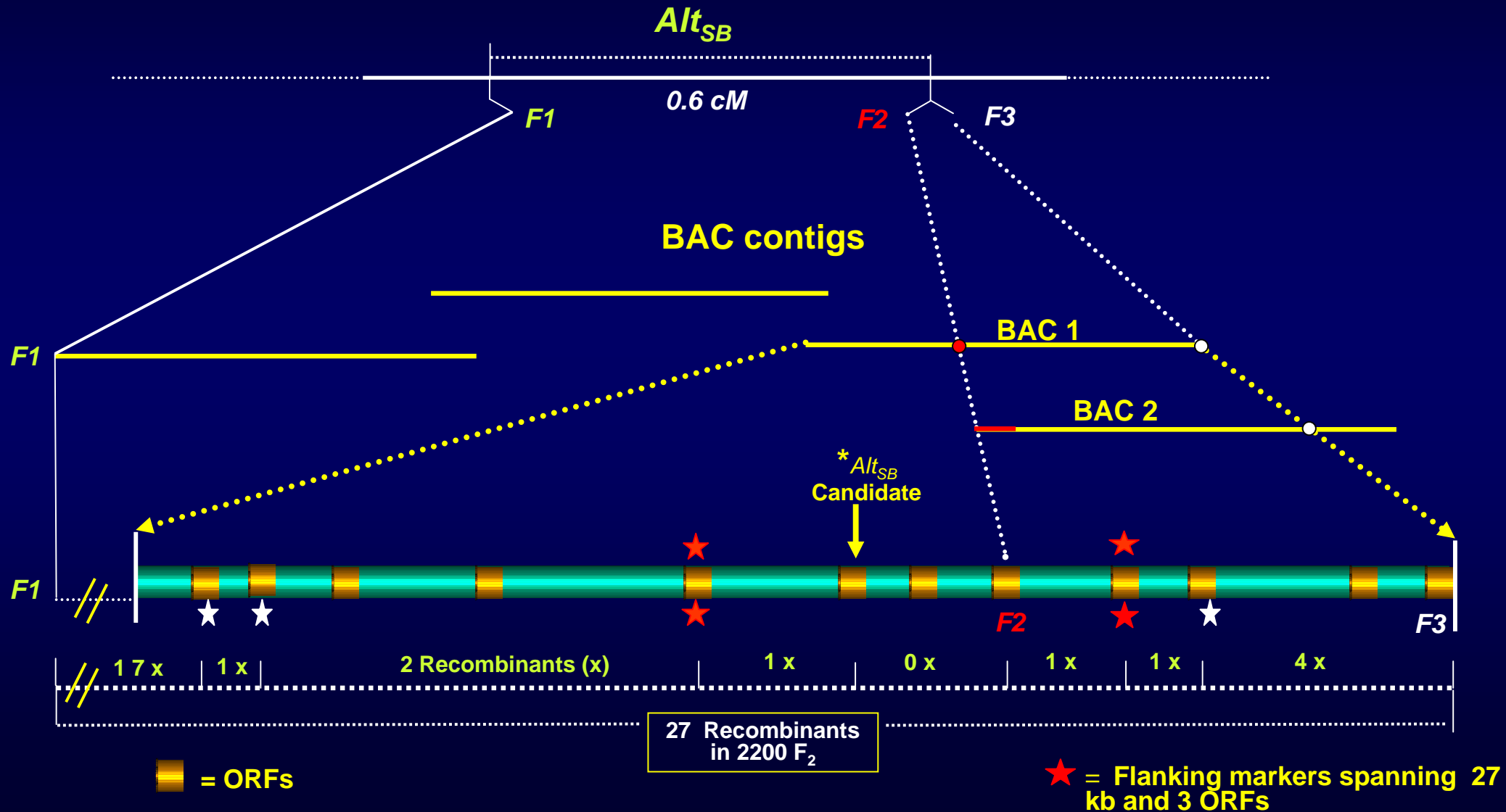

# Physiological Aspects of Sorghum Al Tolerance

Al tolerance is inducible over time of exposure to Al

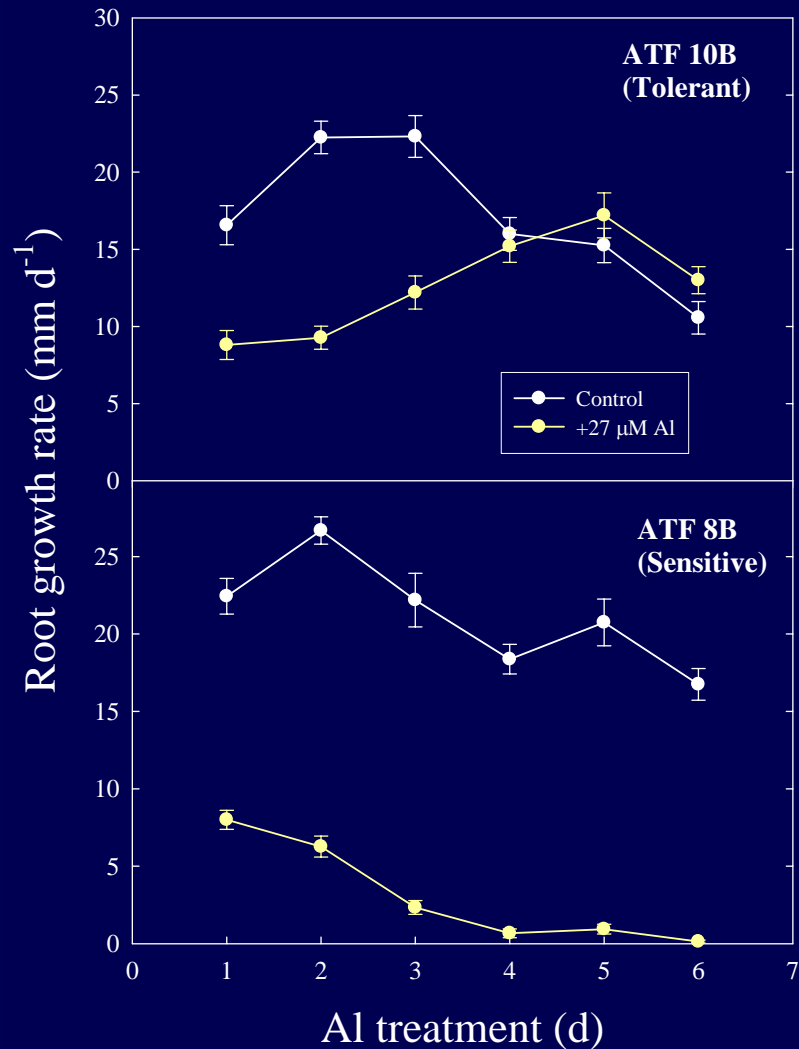

Root citrate efflux is inducible by Al and over time of exposure to Al

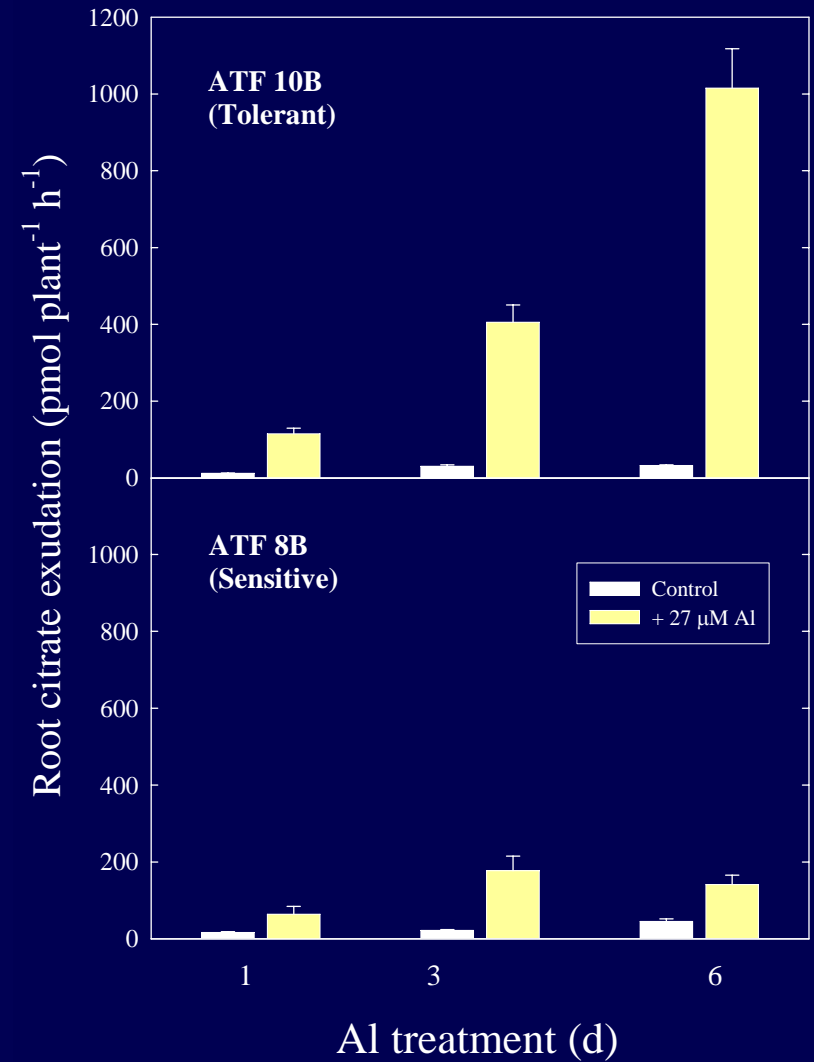

# Temporal Expression of $Alt_{SB}$ Candidate in Root Tips of Al Tolerant and Sensitive NILs

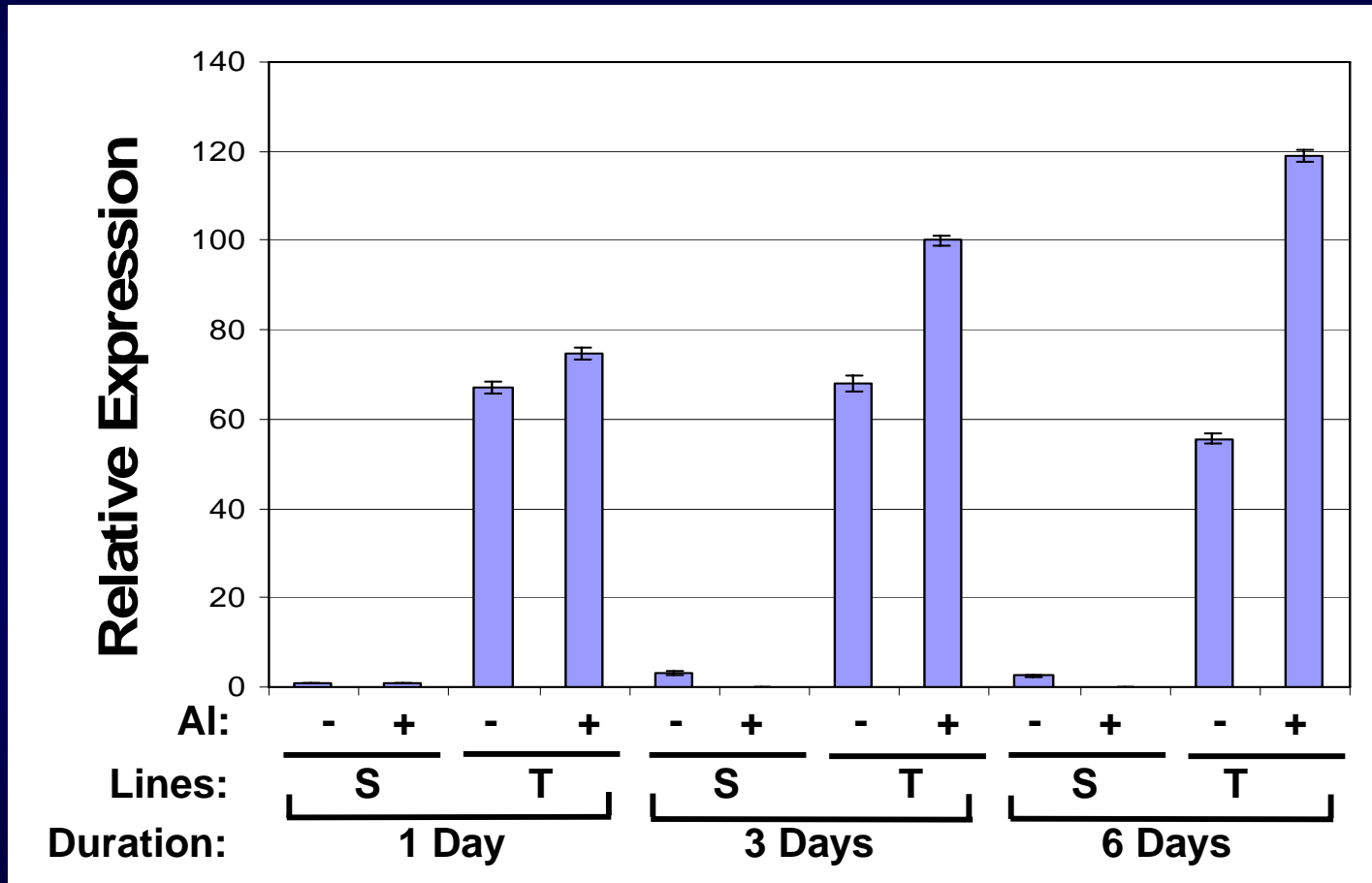

Quantitative real time PCR on root tips from Al tolerant (T) and sensitive (S) near isogenic lines exposed to Al from 1, 3 and 6 days

# Spatial Expression of $Alt_{SB}$ Candidate in Root Tips of Al Tolerant and Sensitive NILs

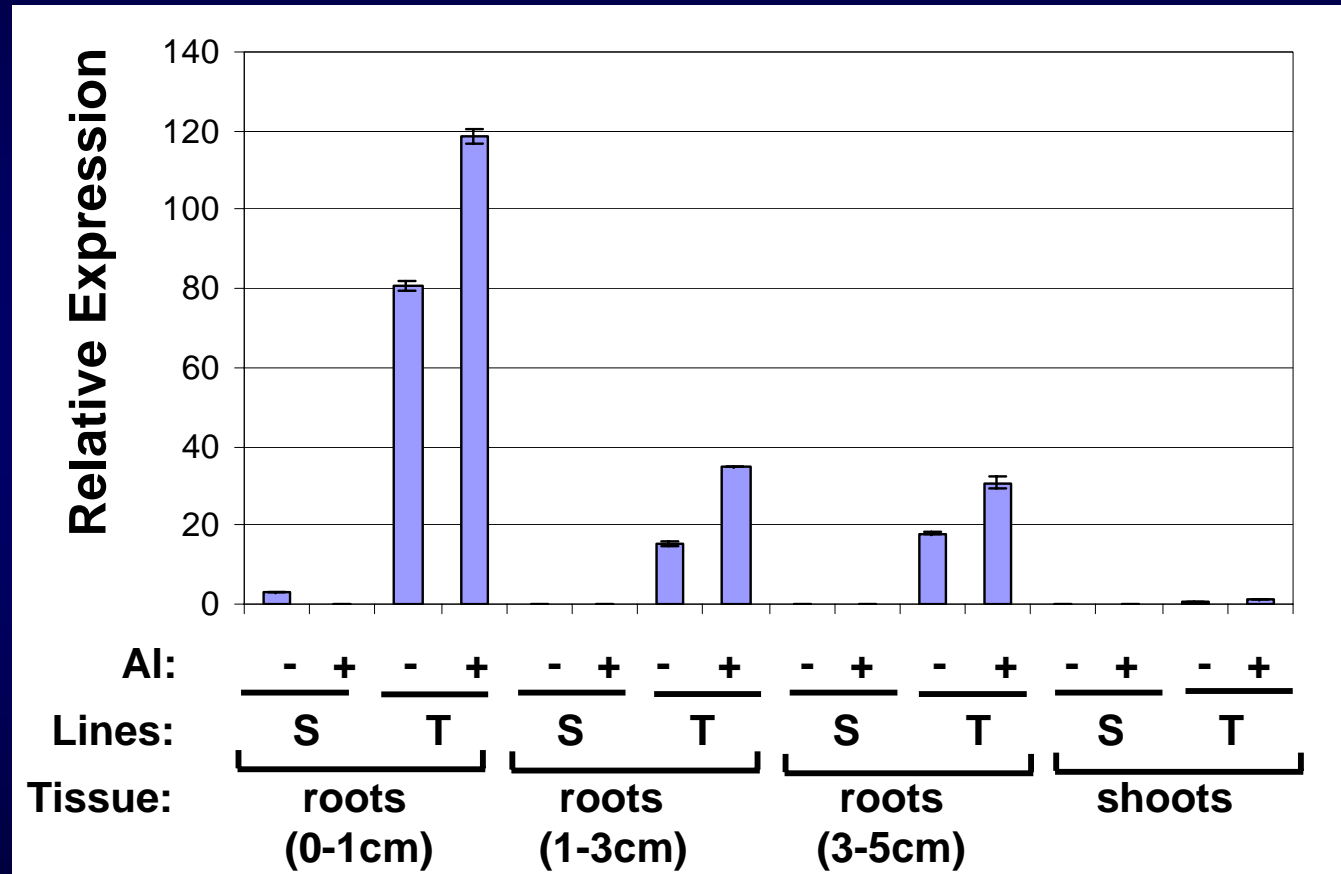

Quantitative real time PCR on root and shoot tissue from Al tolerant (T) and sensitive (S) near isogenic lines exposed to Al for 3 days

# Spatial Expression of ORFs 8 and 9 in Roots and Shoots (Semi-quantitative RT-PCR)

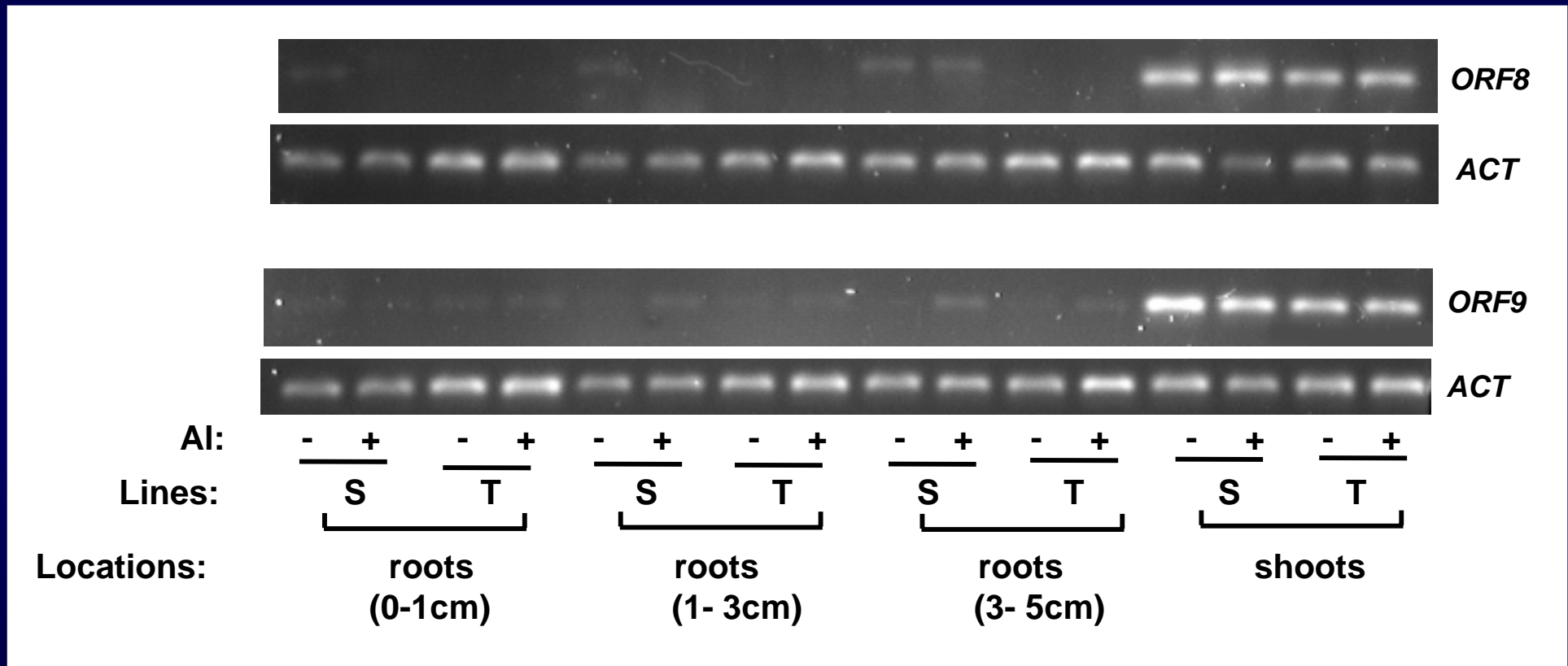

ORFs 8 and 9 are not expressed in the root tips, where Al tolerance mechanisms take place

# Cellular Basis of Aluminum Tolerance

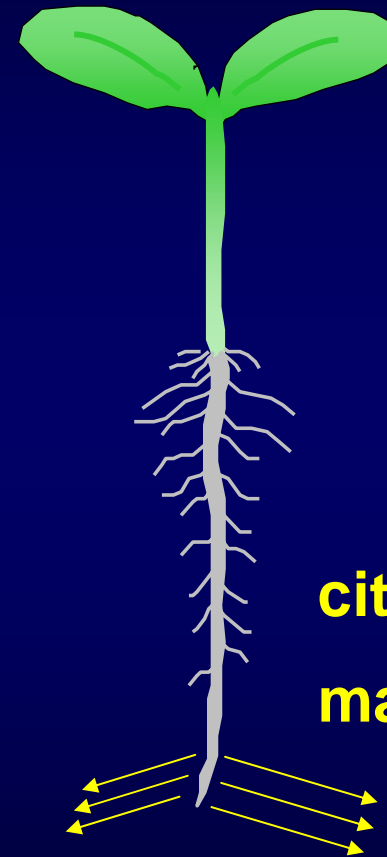
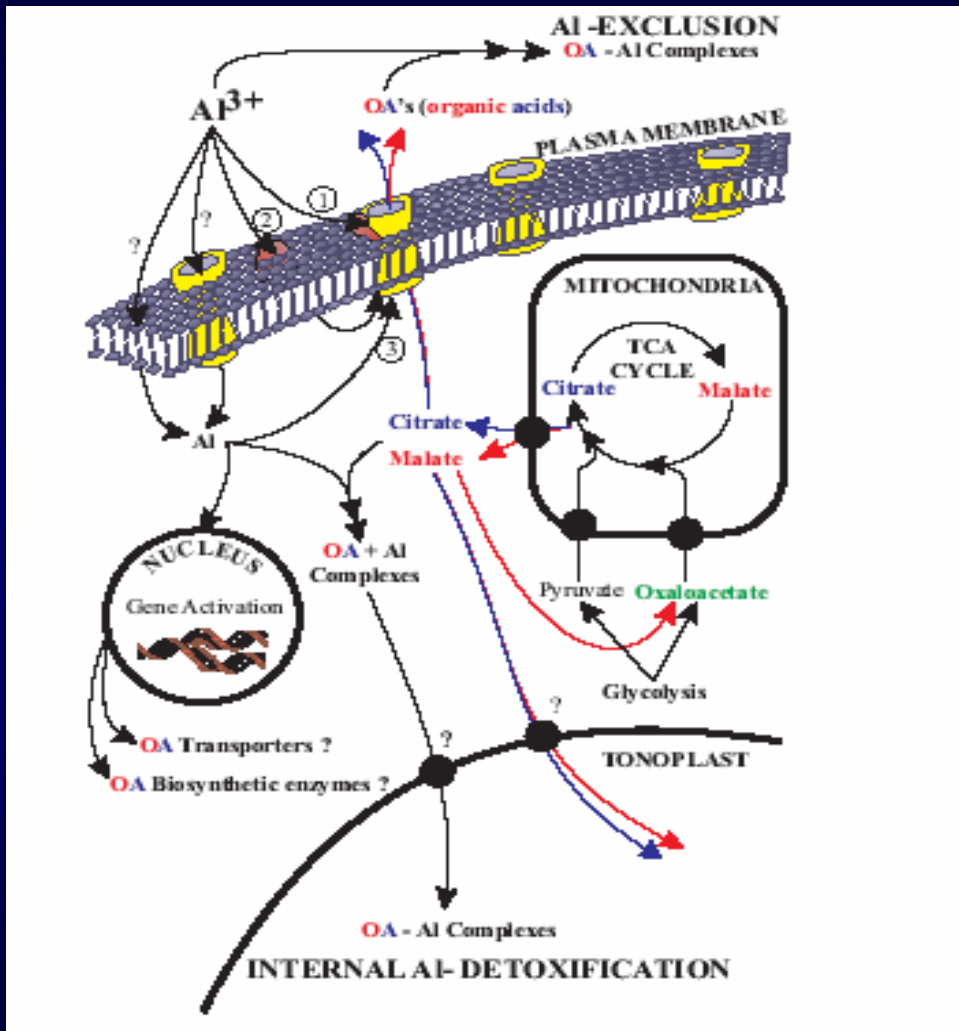

(*Alt<sub>SB</sub>*, Andropogoneae)

**Al-citrate**

**citrate + Al<sup>3+</sup>**

**malate + Al<sup>3+</sup>**

**Al-malate**

(*Almt-1*, Triticeae)

# Are there other sorghum Al tolerance genes that are agronomically relevant?

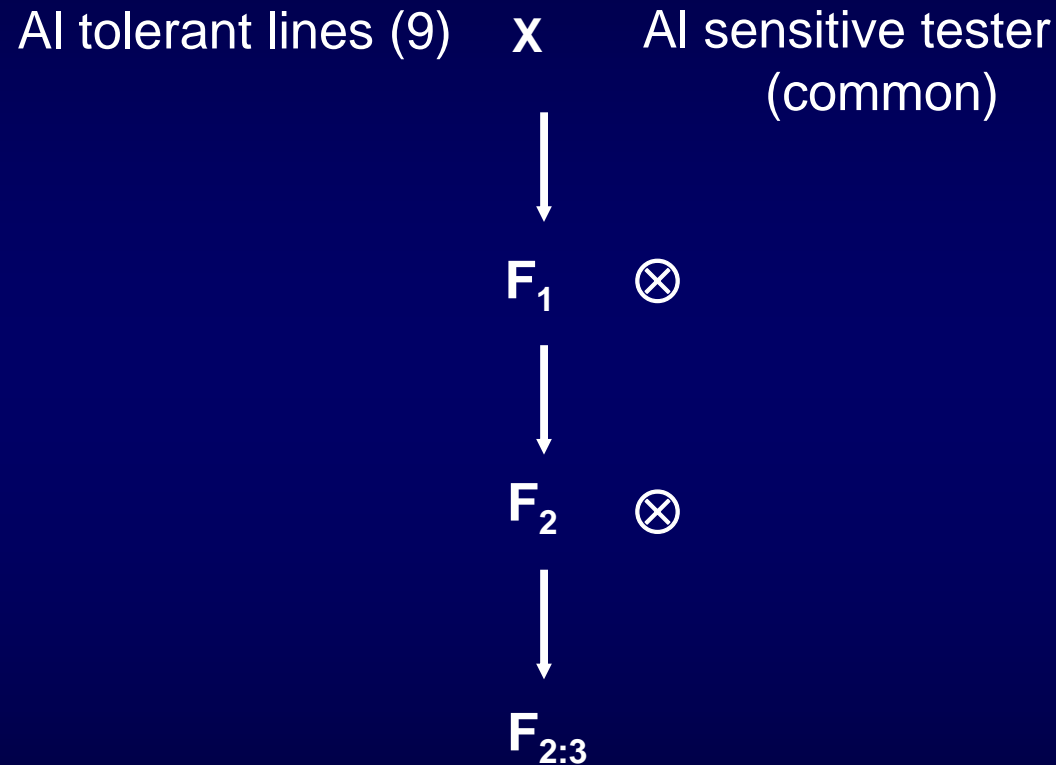

# Intra-Specific Diversity for Al Tolerance in Sorghum

Sorghum lines	Percent Root Growth (+Al/-Al)				Linkage to <i>Alt<sub>SB</sub></i>	Putative Alleles
	{11}μM Al <sup>3+</sup>	{20}μM Al <sup>3+</sup>	{27}μM Al <sup>3+</sup>	{39}μM Al <sup>3+</sup>		
BR007B	45 a	21 a	16 a	9 a	-	I
BR0012R	87 b	53 b	35 b	20 a	✓	II
IS8577	113 b	79 c	54 b	29 a	✓	III
SC112-14	106 b	82 c	45 b	18 a	No	--
SC549	100 b	91 c	74 c	50 b	✓	IV
3DX57/1/1/910	116 b	95 c	70 c	52 b	✓	IV
5DX-61-6-2	125 b	113 d	96 d	56 b	No	--
9DX9/11	99 b	82 c	70 c	63 c	✓	IV
SC175-14	105 b	100 d	85 c	78 c	✓	V
CMSXS225R	94 b	109 d	109 d	82 c	✓	V
SC566-14	123 b	104 d	105 d	98 d	✓	VI or VII
SC283	103 b	114 d	112 d	108 d	✓	VI
CV(%)	14,30	8,64	15,19	20,04		

- Genetic analysis done with F<sub>2</sub> of cross between each sorghum lines x BR012R
- Putative allelic series: validation with NILs, sequence and expression analysis
- Two new sources of Al tolerance for Al tolerance gene pyramidation

# Significant Allelic Variation at $Alt_{SB}$ Locus

Tester: BR012R  
(recurrent)

x

Tolerant sources  
(donors)

Homozygous  $BC_3F_5$   
Near-isogenic lines (~94%)

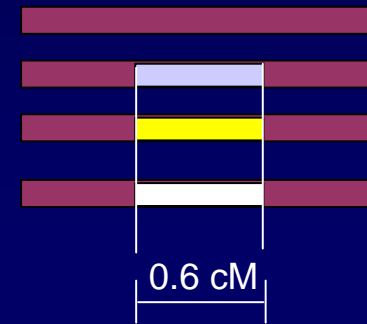
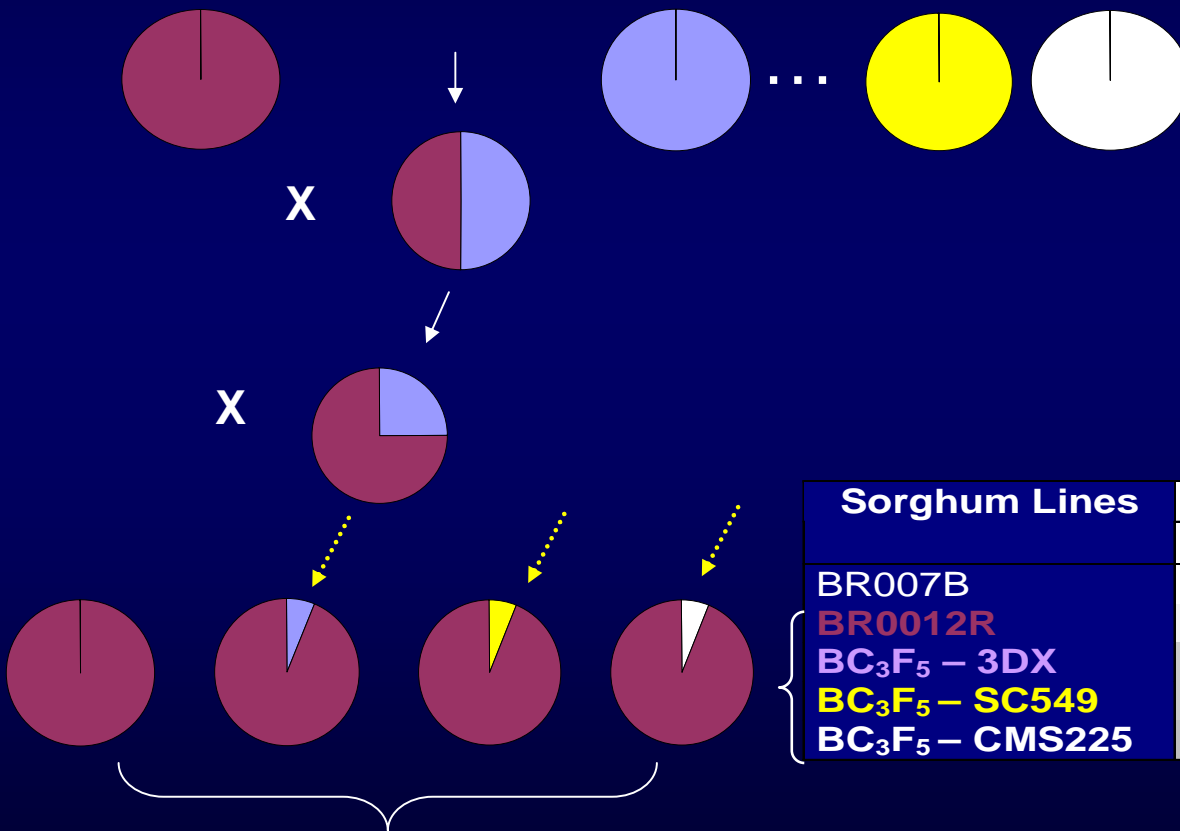

ctg29 m181

Sorghum Lines	Percent Root Growth (+Al/-Al)			
	{11}μM Al	{20}μM Al	{27}μM Al	{39}μM Al
BR007B	58	18	11	8
BR0012R	93	45	22	16
$BC_3F_5$ – 3DX	88	60	33	18
$BC_3F_5$ – SC549	93	70	35	19
$BC_3F_5$ – CMS225	103	77	70	61

Deliverable: Isogenic  
Hybrids

# Diversity for AI Tolerance in Sorghum

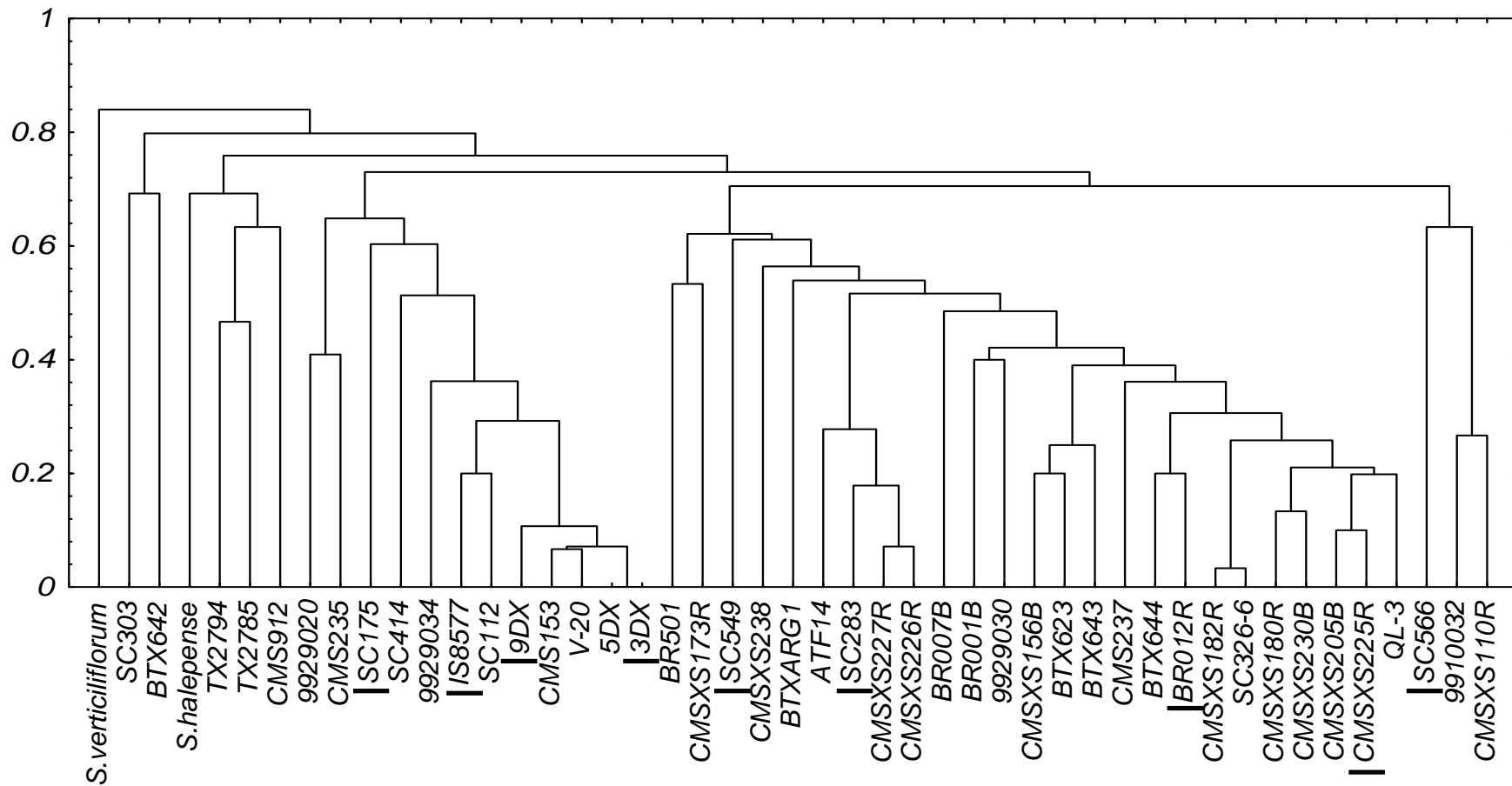

# Verification of $Alt_{SB}$ Candidate as Bona Fide AI Tolerance Gene

- Haplotype Analysis:

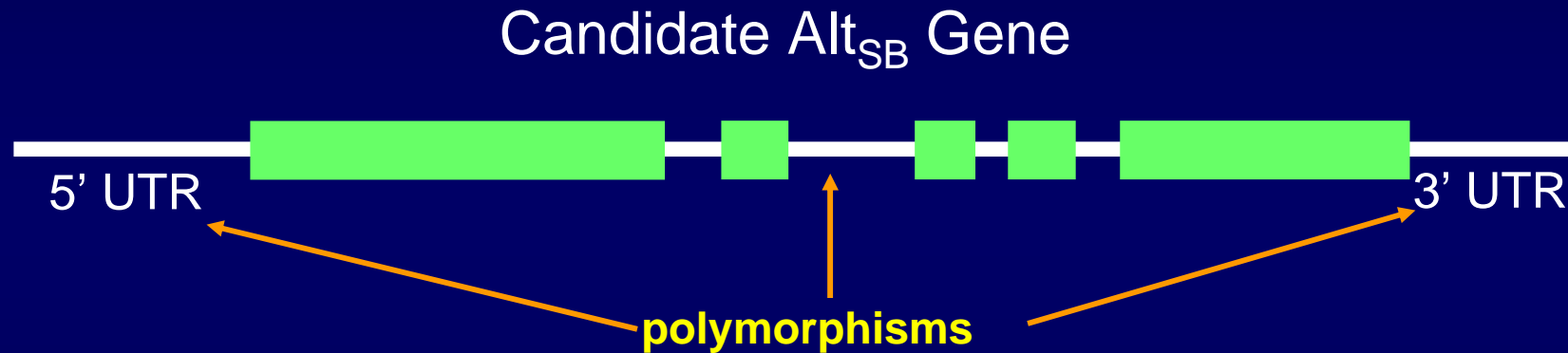

- No differences in the coding region of  $Alt_{SB}$  between SC283 and BR007
- Polymorphisms in one intron as well as in the 5' and 3' UTR apparently not associated with differences in AI tolerance
- However promoter region is quite interesting ...

# Haplotype Analysis of *Alt<sub>SB</sub>*

Differences in the size of amplification fragments of the promoter region of *Alt<sub>SB</sub>* in the sorghum lines

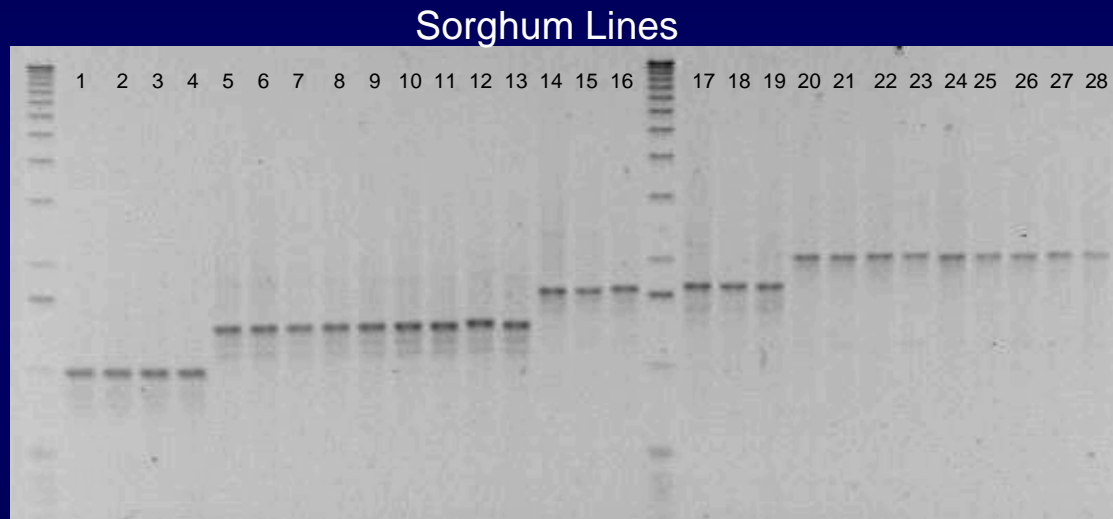

- A transposon insertion in the promoter region of *Alt<sub>SB</sub>* causes pronounced allelic size variation (from 800-3000 bp) in the sorghum panel with different levels of AI tolerance

# Haplotype Analysis of $Alt_{SB}$

Linear Regression Analysis: RRG x Insertion Size (n=41)

$$RRG = - 80.4 + 0.07633bp \quad (r^2=0.57^{**})$$

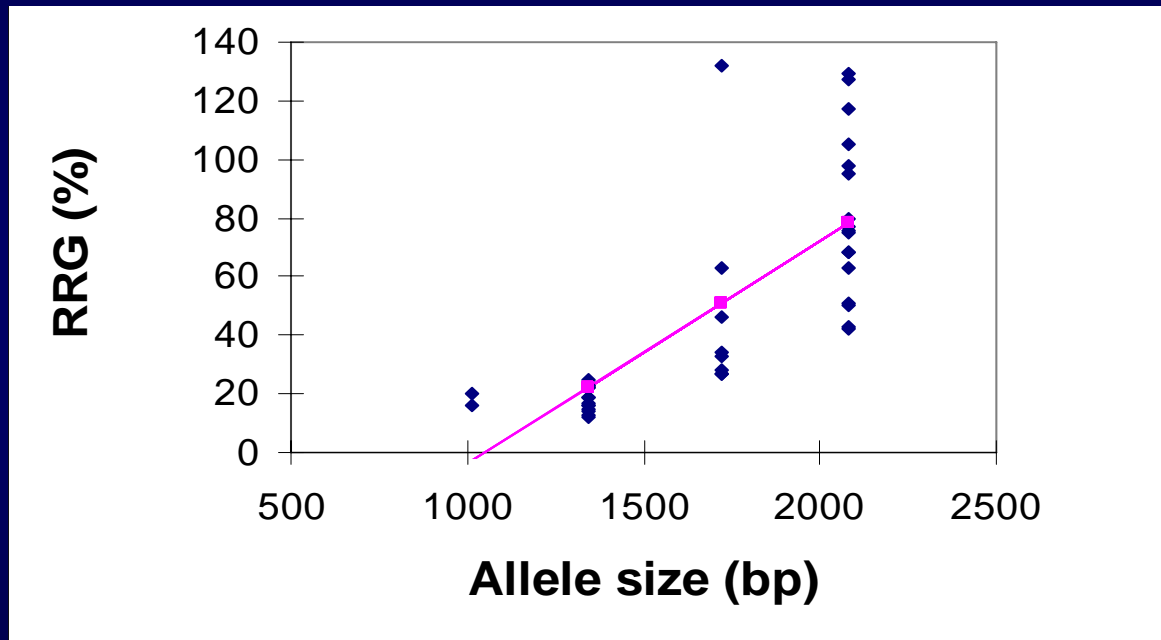

- Preliminary analysis suggests that size of transposon insertion is strongly associated with the AI tolerance in the sorghum panel.
- Multiple repeats acting as enhancer of gene expression?
- Specific sequence motifs might also be involved.

# Haplotype Analysis of $Alt_{SB}$

- Does size variation fully explain high levels of allelic variation ? -

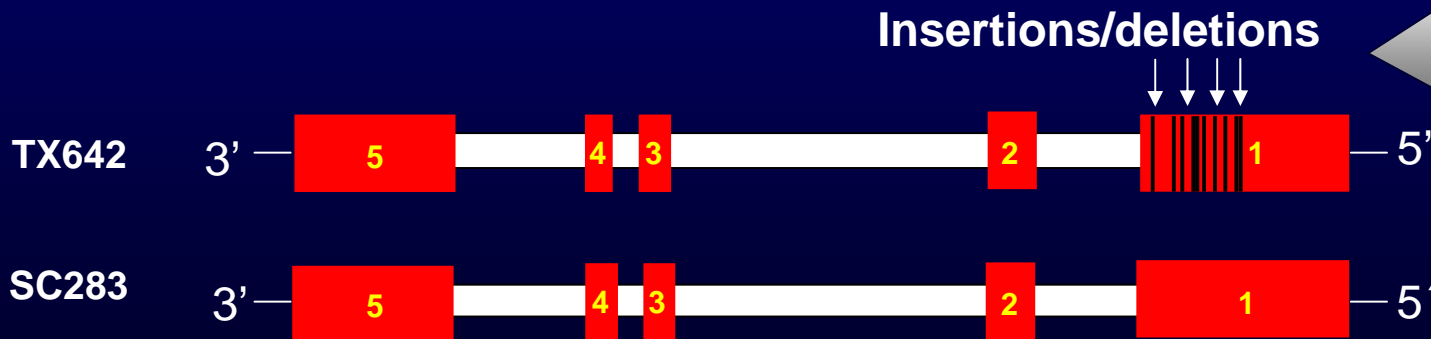
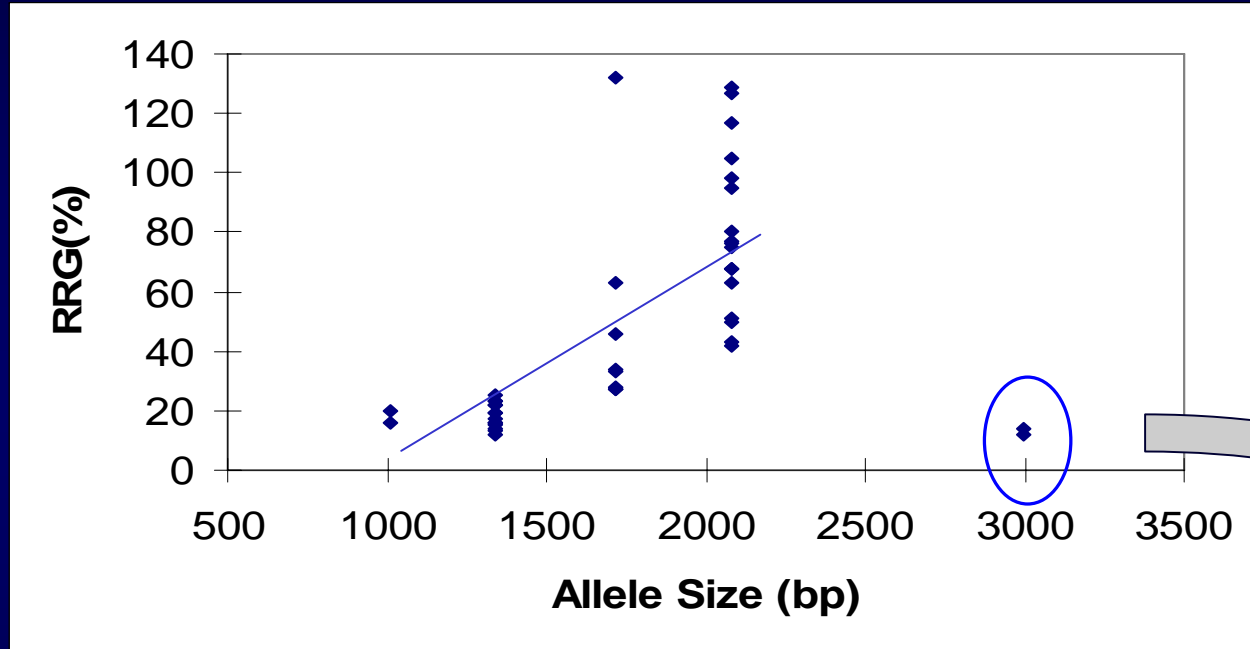

# Ongoing and Future Sorghum Research

- Association analysis
  - Fully sequence variable region in promoter from diversity panel
  - Association analysis with the CIRAD panel (300 lines) correlating sequence with root growth,  $Alt_{SB}$  expression, and root citrate exudation
  - Identify best alleles for crop improvement: Tx642 promoter::SC283 coding region?
- Expression of tolerant allele in transgenic sorghum, maize, wheat and Arabidopsis (Al sensitive genotypes)
- Study the function of wheat ( $Almt-1$ ) and sorghum ( $Alt_{SB}$ ) genes within the same maize and sorghum genetic background:
- $Alt_{SB}$  candidate appears to be a novel transporter:  
Electrophysiological analysis following heterologous expression in oocytes, mammalian cells and transgenic plants
- Promoter analysis to understand differences in expression and also Al inducibility:  
transient expression assays and association analysis
- Study homologs in maize and other grasses as candidates for Al tolerance in those species



**1st Year Research Progress:**

**Maize Aluminum Tolerance**

# QTL Mapping of Al Tolerance

- Tropical (Cateto x L53) and temperate (IBM or Intermated B73 x Mo17) populations
- Cateto and L53 represent extremes of Al tolerance: 5 Al tolerance QTL and 60% of the variation in an  $F_{3:4}$  population (Ninamango-Cárdenas et al. Euphytica 130:223-232, 2002)
- Parents of the IBM population are relatively Al sensitive, yet represent extremes in root citrate exudation
- QTL mapping of this temperate population also yielded 5 Al tolerance QTL explaining 60% of the variation in Al tolerance

**Mason *et al.* and Jardim *et al.***

# Some Overlap Between Maize QTL Studies

Allelic diversity temperate vs. tropical?

## Temperate IBM

## Tropical CatxL53 RILs

Genome Location	Marker	Location	R <sup>2</sup>	Candidate Gene
	bnlg1179	1.01	7.62	
3.04	phi064	1.11	5.71	
3.07	<b>mmc0312</b>	<b>3.04</b>	<b>6.47</b>	<i>Alt<sub>SB</sub></i>
4.01	bnlg105	5.02	6.14	<i>Almt-1</i>
8.04	bnlg161	6.00	4.83	<i>Alm-2</i>
10.00	umc1018	6.05	9.66	
	<b>dupssr14</b>	<b>8.07</b>	<b>8.25</b>	<i>Alt<sub>SB</sub></i>

# Ongoing and Future Maize Research

---

- In process of generating near-isogenic lines (NILs) for each QTL (Temperate and Tropical)
- These NILs will be excellent resource for identifying novel Al tolerance mechanisms (physiology): explore deviations from the trend  $\uparrow$  organic acid release vs.  $\uparrow$  Al tolerance
- Use genomic and proteomic analysis as well as fine scale mapping of NILs to identify possible candidate tolerance genes
- Use natural diversity (association analysis) and transgenic approaches to verify candidate genes
- Use natural diversity to find elite alleles
- Map the genes differently expressed on microarrays
- Saturating the tropical map with SSRs and anchor markers (linked to Al tolerance genes in other species)
- Field experiments to map grain yield under Al stress

# Maize Tropical Mapping Population

Contrasting parental inbred lines:

Tolerant: Cateto

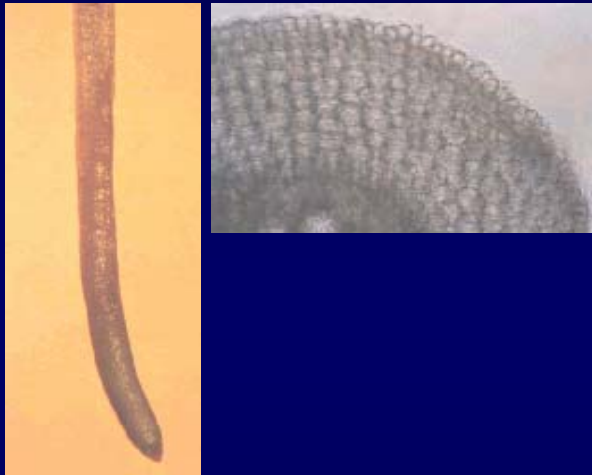

Seminal root under nutrient solution with Al stress

Agronomic performance under field conditions



Sensitive: L53



Segregating populations: 168 F<sub>3:4</sub> and 120 RILs (S<sub>7</sub>)

# Maize Microarray Pilot Study

---

- Experiment with 2 AI tolerant and 2 sensitive maize lines using maize oligonucleotide microarrays
- Looked for genes highly expressed under both +/- AI conditions in root tips of tolerant x sensitive maize lines
- Several candidate genes identified from microarray were submitted to association analysis using Dr. Buckler's panel of 288 diverse maize genotypes
- Two of them showed a significant association between AI tolerance and specific SNPs in these genes

# Maize Microarray Pilot Study

---

- One these genes may be involved in cell wall composition and thus may describe a novel tolerance mechanism while a second is involved in organic acid metabolism
- We also have identified a gene strongly induced by Al specifically in root tips of the tolerant lines that is a close homolog of our candidate for *Alt<sub>SB</sub>* in sorghum (Lyza Maron)
- This may be the Al-activated citrate efflux transporter in maize roots and thus may play a major role in maize Al tolerance.

## Maize Chromosome 3

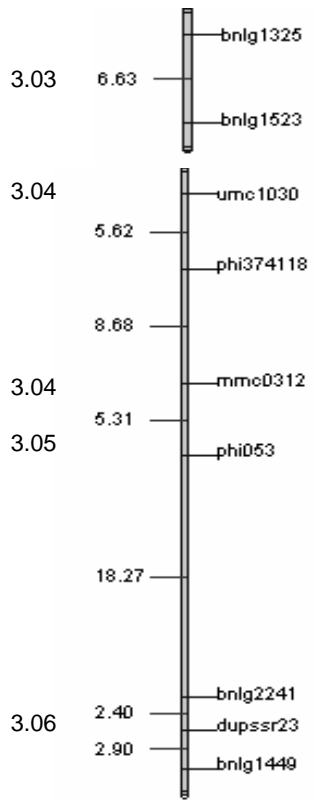

## Maize Chromosome 8

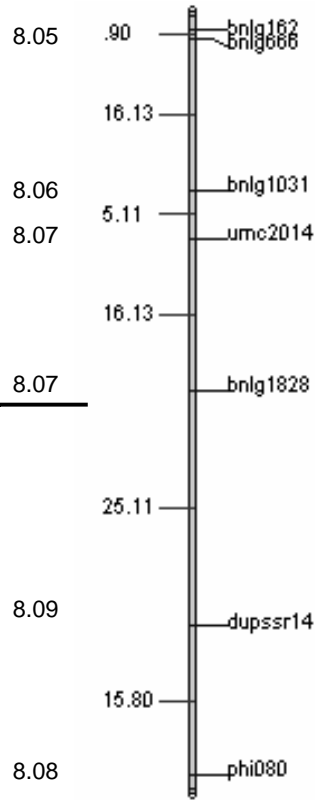

- QTL for RSRL in a RIL population
- QTL for NSRL in a F<sub>3:4</sub> population

## Rice Chromosome 1

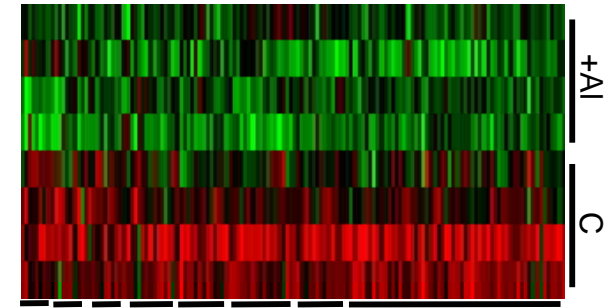
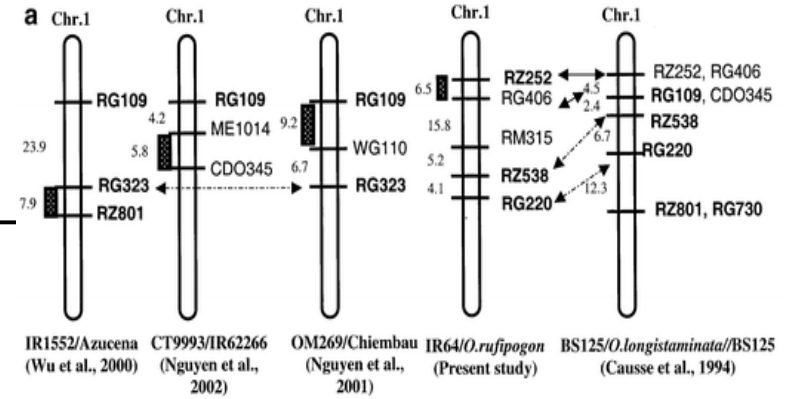

## Sorghum Chromosome 3

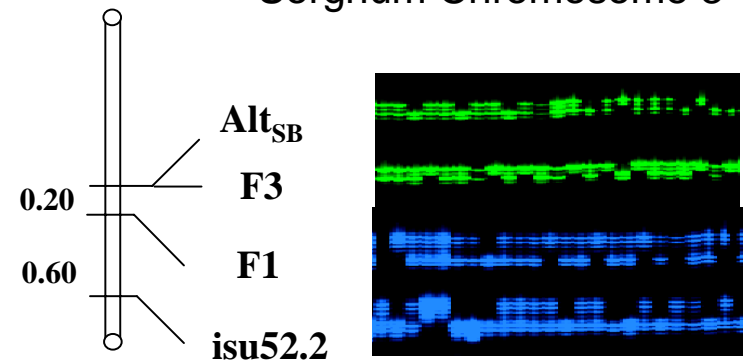

# Funding

- ❖ The Generation Challenge Program (IC69)
- ❖ The McKnight Foundation CCRP Project
- ❖ U.S. National Science Foundation
- ❖ EMBRAPA
- ❖ USDA-Agricultural Research Service